

**BBS-10  
Ball Check Valves  
Weld End**

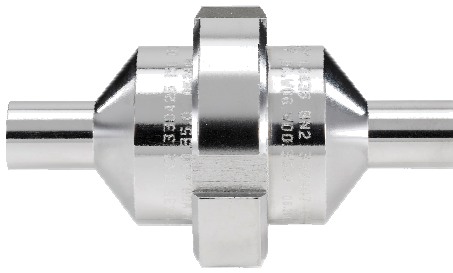

**Ball check valve designed for continuous flushing to suit hygienic applications**

- Fully traceable materials
- Various process connections available
- Suitable for CIP and SIP
- Design means flow direction can be reversed

Hygienic Processing Components.....



**Type BBS-05**  
Quick Connect

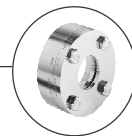

**Type BBS-07**  
Block Flange



**Type BBS-03F**  
Flow Indicator



**Type 2103**  
Diaphragm Valve



**Type 8221**  
Conductivity

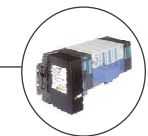

**Type 8650**  
Process Automation

TIS BBS-10 Ball Check Weld End V00.2010 EN

The advanced design of this ball check valve is ideal for applications involving fluids and steam. The unique design allow choice of the flow direction thus significantly enhancing installation cost and simplicity. Meets the new standards and challenges of the Biotechnology and Pharmaceutical industry.

**Typical applications in:**

- Biotechnology
- Pharmaceutical
- Chemical
- Dairy and Food
- Beverage
- Cosmetic

The standard version has an opening pressure of 0.2 Bar but lower pressures can be realized with alternative spring selection.

Technical Overview	
Available Sizes/Standards	ISO DN08 to DN100 BS-OD DN1/4" to DN 6" SMS DN15 to DN100 DIN DN08 to DN100 Larger sizes on request
Body Material	Stainless Steel 316L 1.4435 BN2 Special Materials E.g. Hastelloy on request
Ball	1.4435 BN2 Stainless Steel with PTFE cover
Sealing Material	EPDM, PTFE or Silicone
Process Temperature	-60 to +200 °C
Ambient Temperature	-20 to +80 °C
Media	Gases or Liquids
Media Pressure	-1 to + 16 Bar (working pressure -1 to + 8 Bar)
Certification Available	Material 3.1, FDA, USP VI

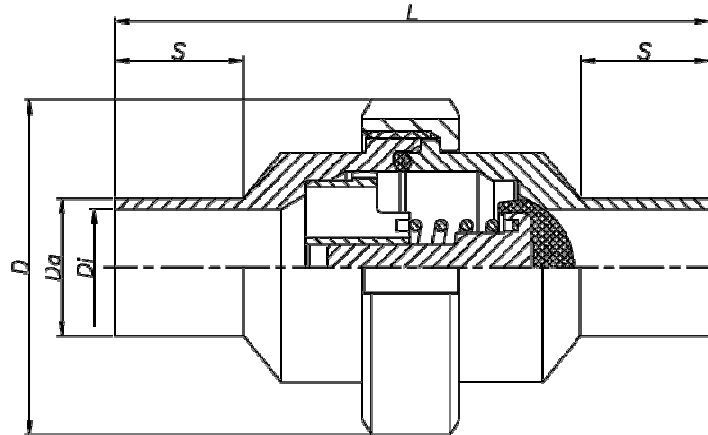

TIS BBS-10 Ball Check Weld End V00.2010 EN

ISO Dimensions of Ball Check Valve / Weld End Connection							
Size	D mm	Da mm	Di mm	L mm	S mm	BBS Item Key (Item No. EPDM)	BBS Item Key (Item No. FEP)
DN 08	52.00	13.50	10.30	92.00	18.00	BBS-10.RU.W08.W08.35.0 (736347)	BBS-10.RU.W08.W08.35.3 (736351)
DN 10	52.00	17.20	14.00	92.00	18.00	BBS-10.RU.W10.W10.35.0 (736359)	BBS-10.RU.W10.W10.35.3 (736363)
DN 15	52.00	21.30	18.10	92.00	18.00	BBS-10.RU.W15.W15.35.0 (736393)	BBS-10.RU.W15.W15.35.3 (736401)
DN 20	67.00	26.90	23.70	105.00	18.00	BBS-10.RU.W20.W20.35.0 (736409)	BBS-10.RU.W20.W20.35.3 (736414)
DN 25	67.00	33.70	29.70	105.00	18.00	BBS-10.RU.W25.W25.35.0 (736433)	BBS-10.RU.W25.W25.35.3 (736438)

BS-OD Dimensions of Ball Check Valve / Weld End Connection							
Size	D mm	Da mm	Di mm	L mm	S mm	BBS Item Key (Item No. EPDM)	BBS Item Key (Item No. FEP)
DN1/4"	52.00	6.35	4.57	92.00	18.00	BBS-10-RU.Y02.Y02.35.0 (736505)	BBS-10-RU.Y02.Y02.35.3 (736568)
DN3/8"	52.00	9.53	7.75	92.00	18.00	BBS-10-RU.Y03.Y03.35.0 (On Request)	BBS-10-RU.Y03.Y03.35.3 (On Request)
DN1/2"	52.00	12.70	9.40	92.00	18.00	BBS-10-RU.Y05.Y05.35.0 (736526)	BBS-10-RU.Y05.Y05.35.3 (736534)
DN3/4"	52.00	19.05	15.75	92.00	18.00	BBS-10-RU.Y07.Y07.35.0 (On Request)	BBS-10-RU.Y07.Y07.35.3 (736543)
DN1"	67.00	25.40	22.10	105.00	18.00	BBS-10-RU.Y10.Y10.35.0 (736555)	BBS-10-RU.Y10.Y10.35.3 (736568)

**NOTE: Larger sizes are available with flanged assembly – please see pages 4 - 6**



TIS BBS-10 Ball Check Weld End V00.2010 EN

SMS Dimensions of Ball Check Valve / Weld End Connection							
Size	D mm	Da mm	Di mm	L mm	S mm	BBS Item Key (Item No. EPDM)	BBS Item Key (Item No. FEP)
DN 06	52.00	8.00	6.00	92.00	18.00	BBS-10-RU.J06.J06.35.0 (On Request)	BBS-10-RU.J06.J06.35.3 (On Request)
DN 08	52.00	10.00	8.00	92.00	18.00	BBS-10-RU.J08.J08.35.0 (On Request)	BBS-10-RU.J08.J08.35.3 (On Request)
DN 10	52.00	12.00	10.00	92.00	18.00	BBS-10-RU.J10.J10.35.0 (On Request)	BBS-10-RU.J10.J10.35.3 (On Request)
DN 15	52.00	18.00	16.00	92.00	18.00	BBS-10-RU.J15.J15.35.0 (736114)	BBS-10-RU.J15.J15.35.3 (736118)
DN 20	67.00	22.00	20.00	105.00	18.00	BBS-10-RU.J20.J20.35.0 (On Request)	BBS-10-RU.J20.J20.35.3 (On Request)
DN 25	67.00	25.00	22.60	105.00	18.00	BBS-10-RU.J25.J25.35.0 (736128)	BBS-10-RU.J25.J25.35.3 (736136)

DIN Dimensions of Ball Check Valve / Weld End Connection							
Size	D mm	Da mm	Di mm	L mm	S mm	BBS Item Key (Item No. EPDM)	BBS Item Key (Item No. FEP)
DN 04	52.00	6.00	4.00	92.00	18.00	BBS-10-RU.V04.V04.35.0 (On Request)	BBS-10-RU.V04.V04.35.3 (736181)
DN 06	52.00	8.00	6.00	92.00	18.00	BBS-10-RU.V06.V06.35.0 (On Request)	BBS-10-RU.V06.V06.35.3 (736185)
DN 08	52.00	10.00	8.00	92.00	18.00	BBS-10-RU.V08.V08.35.0 (736189)	BBS-10-RU.V08.V08.35.3 (736193)
DN 10	52.00	12.00	10.00	92.00	18.00	BBS-10-RU.V10.V10.35.0 (On Request)	BBS-10-RU.V10.V10.35.3 (On Request)
DN 15	52.00	19.00	16.00	92.00	18.00	BBS-10-RU.V15.V15.35.0 (736234)	BBS-10-RU.V15.V15.35.3 (736242)
DN 20	67.00	23.00	20.00	105.00	18.00	BBS-10-RU.V20.V20.35.0 (736254)	BBS-10-RU.V20.V20.35.3 (736258)
DN 25	67.00	29.00	26.00	105.00	18.00	BBS-10-RU.V25.V25.35.0 (On Request)	BBS-10-RU.V25.V25.35.3 (On Request)

**NOTE: Larger sizes are available with flanged assembly – please see pages 4 - 6**

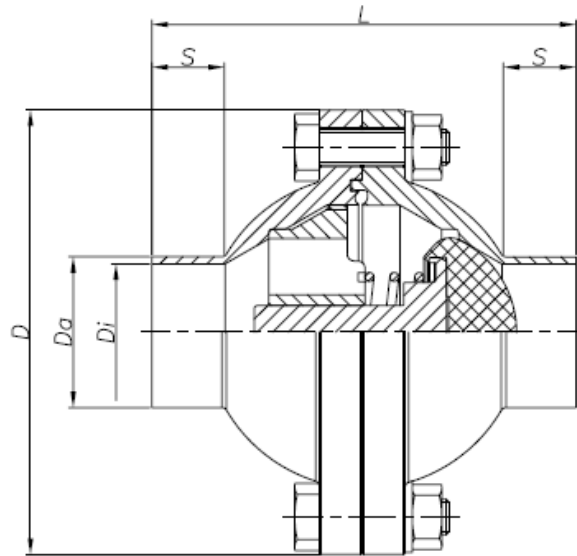

TIS BBS-10 Ball Check Weld End V00.2010 EN

ISO Dimensions of Flanged Assembly Ball Check Valve / Weld End Connection							
Size	D mm	Da mm	Di mm	L mm	S mm	BBS Item Key (Item No. EPDM)	BBS Item Key (Item No. FEP)
DN 25	88.00	33.70	29.70	105.00	20.00	BBS-10-RU.W25.FLK.35.0 (On Request)	BBS-10-RU.W25.FLK.35.3 (736426)
DN 32	125.00	42.40	38.40	119.00	20.00	BBS-10-RU.W32.FLK.35.0 (On Request)	BBS-10-RU.W32.FLK.35.3 (736446)
DN 40	137.00	48.30	44.30	137.00	20.00	BBS-10-RU.W40.FLK.35.0 (On Request)	BBS-10-RU.W40.FLK.35.3 (736467)
DN 50	137.00	60.30	56.30	137.00	32.00	BBS-10-RU.W50.FLK.35.0 (On Request)	BBS-10-RU.W50.FLK.35.3 (736480)
DN 65	168.00	76.10	72.10	123.00	40.00	BBS-10-RU.W65.FLK.35.0 (On Request)	BBS-10-RU.W65.FLK.35.3 (736493)
DN 80	220.00	88.90	84.30	130.00	40.00	BBS-10-RU.W80.FLK.35.0 (On Request)	BBS-10-RU.W80.FLK.35.3 (736497)
DN 100	260.00	114.30	109.70	145.00	30.00	BBS-10-RU.W100.FLK.35.0 (On Request)	BBS-10-RU.W100.FLK.35.3 (736368)



TIS BBS-10 Ball Check Weld End V00.2010 EN

BS-OD Dimensions of Flanged Assembly Ball Check Valve / Weld End Connection							
Size	D mm	Da mm	Di mm	L mm	S mm	BBS Item Key (Item No. EPDM)	BBS Item Key (Item No. FEP)
DN 1.1/2"	125.00	38.10	34.80	159.30	38.00	BBS-10-RU.Y15.FLK.35.0 (736572)	BBS-10-RU.Y15.FLK.35.3 (736580)
DN 2"	137.00	50.80	47.50	180.40	38.00	BBS-10-RU.Y20.FLK.35.0 (736596)	BBS-10-RU.Y20.FLK.35.3 (736600)
DN 2.1/2"	168.00	63.50	60.20	163.00	38.00	BBS-10-RU.Y25.FLK.35.0 (736608)	BBS-10-RU.Y25.FLK.35.3 (736612)
DN 3"	168.00	76.20	72.90	163.00	38.00	BBS-10-RU.Y30.FLK.35.0 (736616)	BBS-10-RU.Y30.FLK.35.3 (736620)
DN 4"	220.00	101.40	97.38	185.00	38.00	BBS-10-RU.Y40.FLK.35.0 (736625)	BBS-10-RU.Y40.FLK.35.3 (736629)
DN 6"	245.00	152.40	148.18	On Request		BBS-10-RU.Y60.FLK.35.0 (736633)	BBS-10-RU.Y60.FLK.35.3 (On Request)

SMS Dimensions of Flanged Assembly Ball Check Valve / Weld End Connection							
Size	D mm	Da mm	Di mm	L mm	S mm	BBS Item Key (Item No. EPDM)	BBS Item Key (Item No. FEP)
DN 32	145.00	32.00	29.60	126.00	24.00	BBS-10-RU.J32.FLK.35.0 (On Request)	BBS-10-RU.J32.FLK.35.3 (On Request)
DN 40	145.00	38.00	35.60	126.00	24.00	BBS-10-RU.J40.FLK.35.0 (On Request)	BBS-10-RU.J40.FLK.35.3 (On Request)
DN 50	157.00	51.00	48.60	128.00	30.00	BBS-10-RU.J50.FLK.35.0 (On Request)	BBS-10-RU.J50.FLK.35.3 (On Request)
DN 65	157.00	63.50	60.30	106.00	30.00	BBS-10-RU.J65.FLK.35.0 (736169)	BBS-10-RU.J65.FLK.35.0 (736177)
DN 80	168.00	76.10	72.90	130.00	30.00	BBS-10-RU.J80.FLK.35.0 (On Request)	BBS-10-RU.J80.FLK.35.3 (On Request)
DN 100	260.00	101.60	97.60	145.00	30.00	BBS-10-RU.J100.FLK.35.0 (On Request)	BBS-10-RU.J100.FLK.35.3 (On Request)



**DIN Dimensions of Flanged Assembly Ball Check Valve / Weld End Connection**

Size	ø D mm	ø Da mm	ø Di mm	ø L mm	S mm	BBS Item Key (Item No. EPDM)	BBS Item Key (Item No. FEP)
DN 32	88.00	35.00	32.00	104.90	22.00	BBS-10-RU.V32.FLK.35.0 (On Request)	BBS-10-RU.V32.FLK.35.3 (On Request)
DN 40	125.00	41.00	38.00	143.00	25.00	BBS-10-RU.V40.FLK.35.0 (On Request)	BBS-10-RU.V40.FLK.35.3 (On Request)
DN 50	137.00	53.00	50.00	147.00	30.00	BBS-10-RU.V50.FLK.35.0 (On Request)	BBS-10-RU.V50.FLK.35.3 (On Request)
DN 65	168.00	70.00	66.00	154.00	35.00	BBS-10-RU.V65.FLK.35.0 (On Request)	BBS-10-RU.V65.FLK.35.3 (On Request)
DN 80	190.00	85.00	81.00	180.00	35.00	BBS-10-RU.V80.FLK.35.0 (On Request)	BBS-10-RU.V80.FLK.35.3 (On Request)
DN 100	240.00	104.00	100.00	179.00	30.00	BBS-10-RU.V100.FLK.35.0 (On Request)	BBS-10-RU.V100.FLK.35.3 (736221)

TIS BBS-10 Ball Check Weld End V00.2010 EN

**Technical Notes:**

- These ball valves are fully reversible by the user/operator meaning they offer ultimate flexibility.
- They are designed and manufactured for continuous flushing but please note these standard design valves require to be mounted in vertical position to achieve full drainability.
- If you require drainability in a horizontal installation please consult our technical information sheet BBS-10 Eccentric Ball Check Valves. These unique products are designed to mounted in horizontal pipe work and be fully drainable whilst maintaining the features of the standard check valves.
- All valves are suitable for CIP or SIP processes; subject to application the internal components of these valves may also require cleaning out of place. If you are concerned about their suitability for your application please contact our local sales office for a detailed consultation.